

Temcana Kestrel 400 Super Economy

**Power Flued
Fanned Convactor Heater**
Installation and Servicing Instructions



Vulcana Gas

30 Bridge Road, Haywards Heath, West Sussex, RH16 1TX

Tel: 01444 415871 • Fax: 01444 441433

Email: sales@vulcanagas.co.uk • Website: www.vulcanagas.co.uk

INDEX OF CONTENTS

- 1.0 INTRODUCTION
- 2.0 WARRANTY NOTE
- 3.0 CONTENTS LIST
- 4.0 TECHNICAL DATA
- 5.0 SITING HEATER
- 6.0 FLUE TERMINAL POSITIONS
- 7.0 INSTALLATION
- 8.0 GAS CONNECTION
- 9.0 ELECTRICAL
- 10.0 COMMISSIONING AND TESTING
- 11.0 USER INSTRUCTIONS
- 12.0 SERVICING INSTRUCTIONS

1.0 INTRODUCTION

The Temcana Kestrel 400 Super Economy is a forced draught, balanced-flued appliance with fanned convection discharge.

This appliance has been tested and certificated for use on natural gas (G20 at a supply pressure of 20mbar) and propane (G31 at a supply pressure of 37mbar) in GB and IE.

It is designed to be floor standing and does not require any special floor or wall protection. It must be flued directly to external air using only the flue components provided.

With the standard kit provided (see Fig. 1) the heater must be installed with the centre of the hole through the wall as shown in Fig. 3.

This appliance must be installed by a competent person in accordance with these instructions and the following:-

Gas Safety (Installation and Use) Regulations: 1998.

B.S. 6891: 1988

B.S. 5871: Part 1: 1991

B.S. 5440: Part 1: 1990

B.S. 5440: Part 2: 1989

Building Regulations issued by the Dept. of the Environment

Building Standards (Scotland) (Consolidation) Regulations

I.E.E. Wiring Regulations

Health and Safety at work etc, Act: 1984.

Any local Gas Region or Local Authority requirements must also be taken into account.

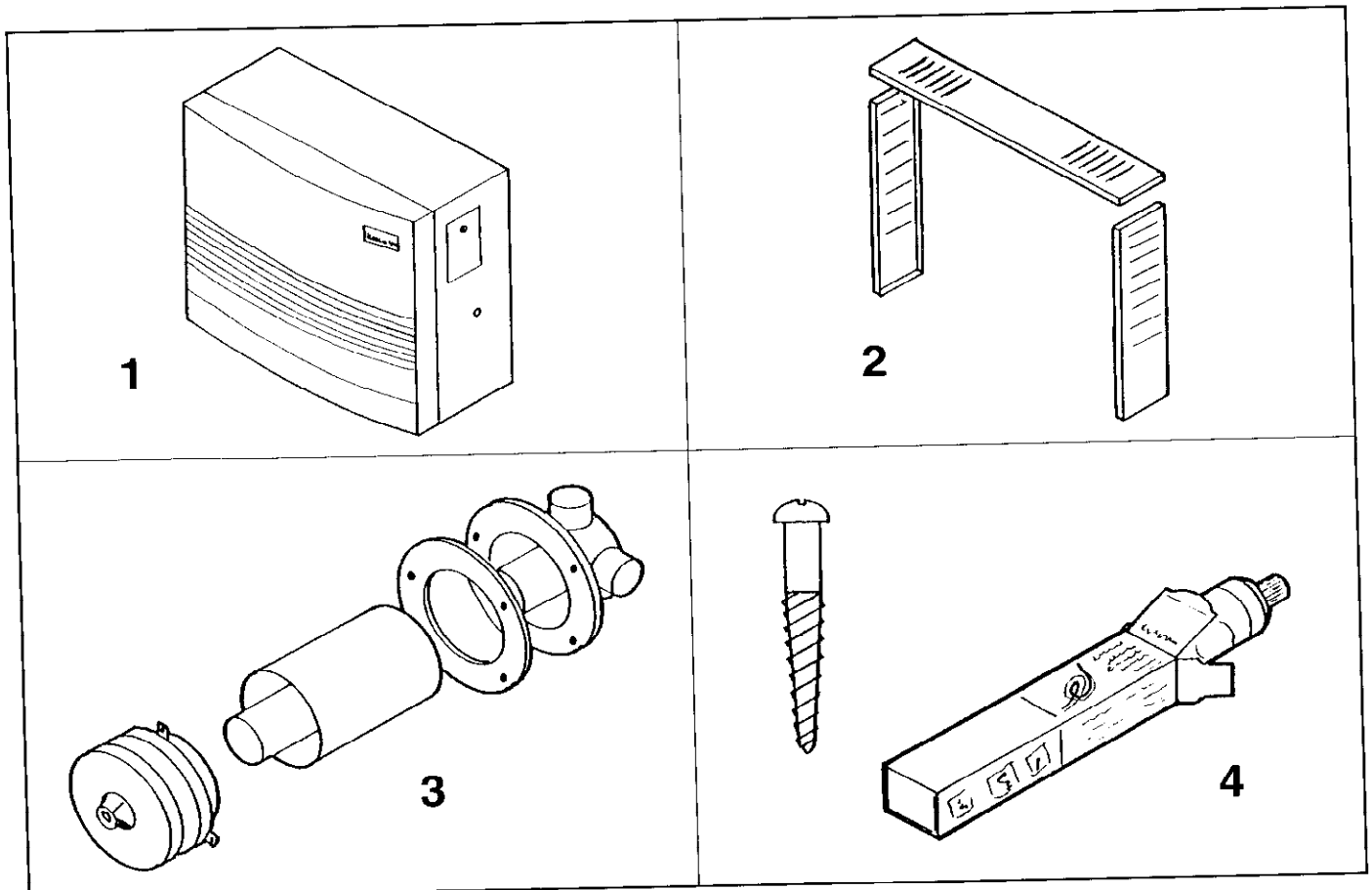

Figure 1

2.0 WARRANTY

Warranty will be invalidated if:-

- The internal wiring is modified in any way.
- The appliance is not installed according to the following instructions or the foregoing requirements.

3.0 CONTENTS LIST

The appliance is despatched as an assembled heater unit complete with accessories.

Identify the various components from Fig. 1 and check to ensure that they are complete and undamaged.

- Heater Unit
- Top, L.H.S. and R.H.S. infill panels (fitted)
- Flue Assembly
- Pack of Screws/Silicone sealant

4.0 TECHNICAL DATA

(A) Natural Gas

Heat Input	14.13 kW (48 200 Btu/h)
Heat Output	11.72kW (40 000 Btu/h)
Inlet Pressure	20 mbar \pm 1 mbar
Burner Pressure (mbar)	12.6
Injector Dia. (mm)	3.1
Weight	60kg
Electrical Supply	230 Volt 50Hz \sim
Electrical Loading (W)	150

(B) Propane

Heat Input	14.13 kW (48 200 Btu/h)
Heat Output	11.72 kW (40 000 Btu/h)
Burner Pressure (mbar)	35.0
Injector Dia. (mm)	1.9
Weight	60kg
Electrical Supply	230 Volt 50Hz \sim
Electrical Loading (W)	150

4.1 Propane Heaters

Warning – The propane gas supply to the heater must be regulated to an inlet pressure of 37 mbar. Failure to regulate the pressure may result in damage to the control valve.

5.0 SITING THE HEATER

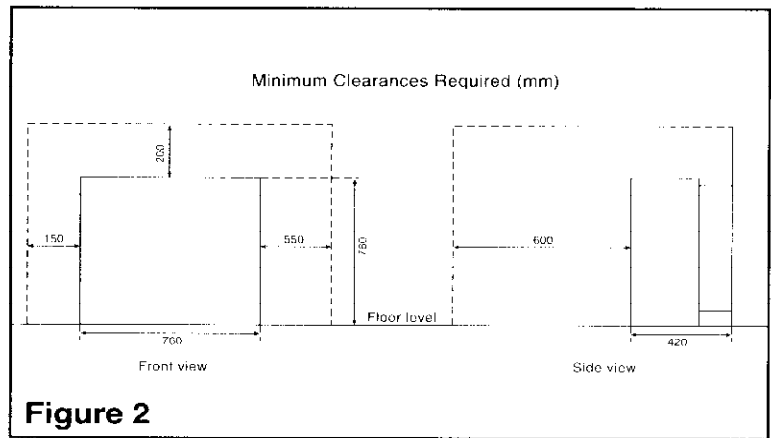

When selecting the site for the heater it is essential to ensure that the flue terminal will also be sited correctly externally (see 6.0 Terminal Position).

- Fig. 2 shows the minimum clearances required to gain access to and allow possible removal of components. These clearances are also necessary for the normal operation of the heater. The clearance at the right hand side applies particularly to the removal of the convection fan filter and this should be borne in mind when running the gas pipe and electrical supply.
- Generally, the best position for the heater is mid-way along a wall of the room that the heater is to serve. This gives the best circulation effect.
- Care must be taken to ensure that no curtains can be hung over or near the heater, nor any door swung in front of it.

6.0 FLUE TERMINAL POSITION

6.1 Siting

- The terminal must be positioned such that the products of combustion can disperse freely at all times.
- In certain weather conditions the terminal may emit steam and positions where this could cause a nuisance should be avoided.
- The base of the terminal must be a minimum of 300mm above the external ground level.
- The terminal should not be installed in any position that will allow the products of combustion to feed back into adjacent doors or windows. Where the terminal is wholly or partly beneath any opening (that is to say any part of a window capable of being opened, or any ventilator, inlet to a ventilation system or similar openings) ensure that no part of the terminal flue outlet is within 300mm, measured vertically, to the bottom of that opening.
- If a terminal is fitted within 850mm of a plastic gutter, an aluminium shield 1.5 metre long should be fitted to the underside of the gutter, immediately above the terminal position.

- f) Where the terminal outlet of the appliance is less than 2m above the level of any ground, balcony, flat roof or space to which any person has access and which adjoins the wall to which the terminal is fitted, the terminal must be protected by a guard of durable material. (Available as an optional extra).

6.2 Balanced Flue Terminal Position Guide

Terminal Position	Recommended Clearance Min.
i) Directly below an openable window or other opening e.g. air brick	300mm
ii) Below guttering (see also note (e) above)	75mm
iii) Below eaves or balconies	200mm
iv) Above adjacent ground or balcony level	300mm
v) From drain or soil pipes	75mm
vi) From a surface facing the terminal	600mm
vii) From a terminal facing the terminal	1200mm
viii) From internal or external corners	300mm

7.0 INSTALLATION

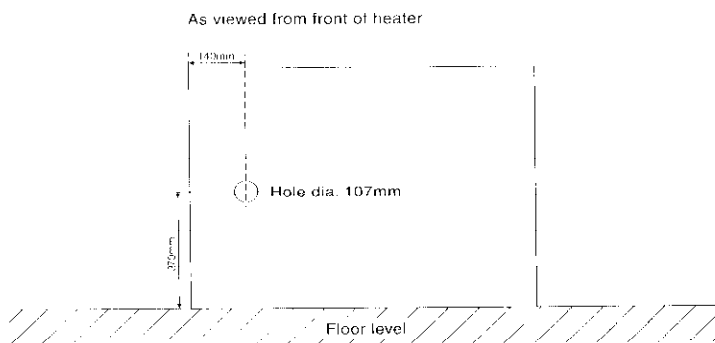

Figure 3

- 7.1** Having chosen the location for the flue assembly and the heater, mark the position for the "hole through the wall" (Fig. 3) on the inner wall face.
- 7.2** Drill a hole 107mm diameter (from inside the building) horizontally right through the wall. If a core drill is not available, cut a hole, as neatly as possible, right through the wall, and make good after fitting the flue assembly.
- 7.3** Temporarily fit the plastic air inlet duct to the manifold, then fit the manifold/air inlet duct to the wall. Ensure that the flue connection (marked) of the manifold is facing upward, then mark the positions for the three fixing screws.
- 7.4** Remove the manifold/air inlet duct and drill and plug the wall as marked to accept the three screws provided.
- 7.5** Fit the gasket to the manifold as shown in Fig 4, then replace the manifold as in 7.3 and secure with the three screws.

- 7.6** From outside the building, insert the plastic air duct through the hole and locate it into the flue manifold; push the air duct fully into the manifold.
- 7.7** Whilst holding the duct square and level, mark it for correct length, i.e. to finish flush with the outside wall surface when cut.
- 7.8** Remove the air duct and cut it to the marked length; make sure that it is cut square and remove any rough edges.
- 7.9** Apply a bead of silicone sealant to the outside surface of one end of the air duct.
- 7.10** Re-insert the air duct and push the end with the sealant firmly into the manifold.
- 7.11** Insert the stainless steel flue tube through the hole and push it firmly onto the flue spigot on the manifold.
- 7.12** Mark the position of the outside wall surface onto the tube (Fig. 4).

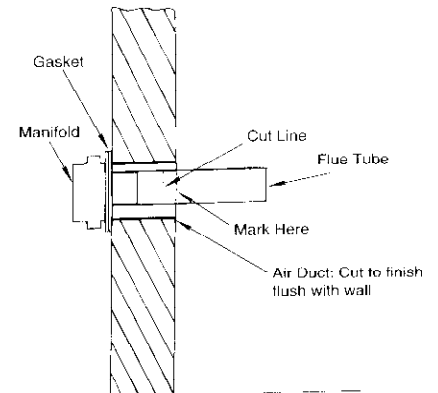

Figure 4

- 7.13** Remove the flue tube and mark a further position 10mm from the previous mark i.e. so that the flue tube will be 10mm short of the outside wall surface when cut.
- 7.14** Cut the flue tube to the correct length. Make sure that it is cut square and remove any rough edges.
- 7.15** Apply a bead of silicone sealant to the inside surface of one end of the flue tube.
- 7.16** Re-insert the flue tube through the hole and push the end with the sealant firmly onto the flue spigot on the manifold.
- 7.17** Place the flue terminal into position, ensuring that the flue and air pipes enter their respective spigots; Mark the position for the three fixing holes and remove the terminal.
- 7.18** Drill and plug the wall in the marked positions to accept the three woodscrews provided.
- 7.19** Apply a bead of silicone sealant to the inside surface of the flue socket and the outside surface of the air spigot on the terminal.
- 7.20** Replace the flue terminal as in 7.17 above and secure it with the three screws provided.

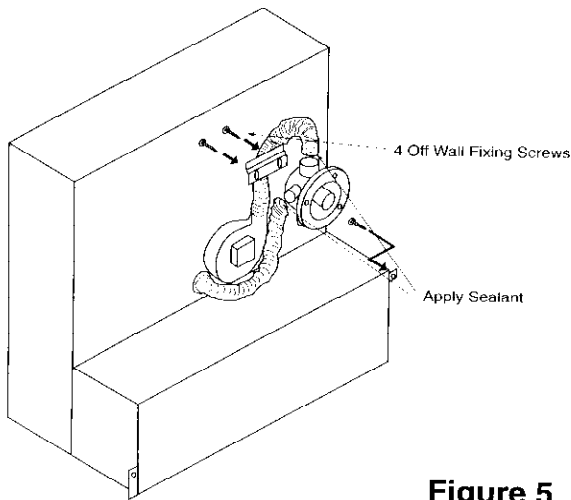

Figure 5

8.0 GAS CONNECTION

The gas connection is 15mm copper tube.

It is essential that a suitable union isolating tap is fitted to the supply in an accessible position adjacent to the heater.

The installation serving the heater must be in accordance with BS 6891: 1988 (For propane BS 5482 Pt.1).

Upon completion, pressure test the gas installation for soundness.

- 7.21 Remove the heater front panel (see 10.1b)
- 7.22 Place the heater into its correct position relative to the hole through the wall (see Fig. 3).
- 7.23 Mark a line on the wall, level with the top infill panel, then remove the three infill panels.
- 7.24 Mark the positions for the two lower fixing brackets and remove the heater from the wall.
- 7.25 Hold the upper restraining bracket centrally and approximately 2mm below the line marked in 7.23 as shown in Fig. 5 and mark the positions for the two fixing holes.
- 7.26 Drill and plug the wall in the marked positions to accept the four woodscrews provided.
- 7.27 Secure the upper restraining bracket to the wall.
- 7.28 Replace the heater as in 7.22 and secure to the wall via the two lower fixing brackets.
- 7.29 Apply a bead of silicone sealant to the inside surface of the flexible aluminium flue hose (connected to combustion fan) and connect the hose to the flue connection of the manifold (marked 'F'). Push the hose firmly onto the flue connection, then tighten the hose clip.
- 7.30 Apply a bead of silicone sealant to the inside surface of the flexible aluminium air inlet hose and connect the hose to the air inlet connection of the manifold. Push the hose firmly onto the air inlet connection, then tighten the hose clip.
- 7.31 If a terminal guard is to be fitted (see 6.1f) it must be positioned centrally over the terminal.

9.0 ELECTRICAL

IMPORTANT – this appliance must be earthed.

All external wiring to the heater must be in accordance with I.E.E. wiring regulations and any local regulations which apply.

The electrical supply required is:-
230 Volt 50Hz ~ Fused at 3A.

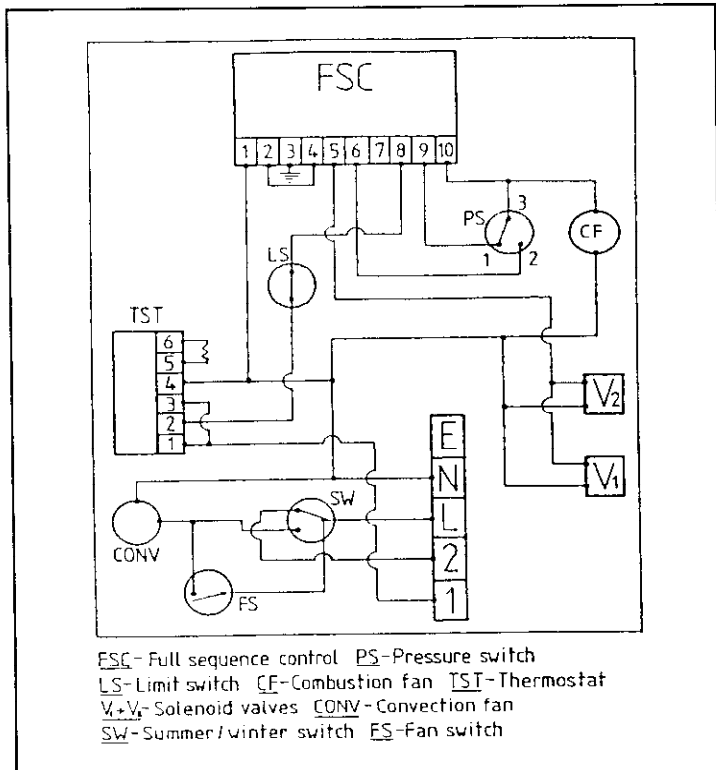

Internal Wiring Diagram

The electrical supply to the heater must not be switched off except when servicing the heater or in an emergency.

There must be no excess cable between the terminal block and the cable gland at the inlet to the heater.

9.1 Controlling the Heater

- A terminal block is provided with two terminals marked 1 and 2 for the connection of an external switching device e.g. time switch.
- These terminals are linked to allow the heater to be commissioned using a temporary lead. The link must be removed when an external switching device is incorporated.
- Do not connect an additional switched live to the heater – terminal 2 is linked, via the summer/winter switch, to live for this purpose.
- If connecting more than one heater to a single time switch, relays must be incorporated as shown in the external wiring diagram below, in order to avoid electrical feed back between heaters.
- Ensure that the cable exits via the opening adjacent to the gas inlet and is anchored using the cable glands provided.
- There must be no surplus cable between the terminal block and the cable gland at the inlet to the heater.

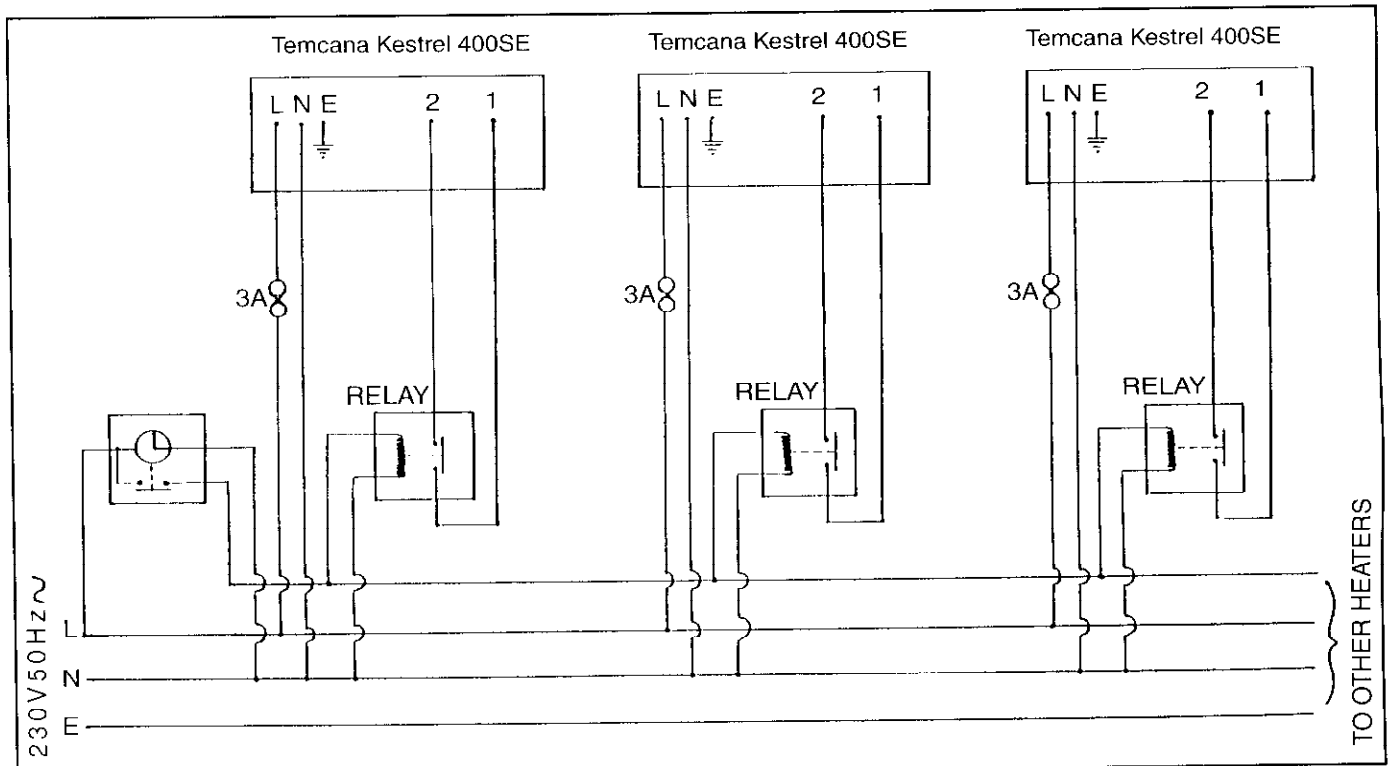

External Wiring Diagram

10.0 COMMISSIONING AND TESTING

Note

The convection fan will not operate until the heater has warmed.

10.1 INITIAL LIGHTING

- a) Ensure that the electrical supply to the heater is switched off.
- b) Remove the two screw covers to expose the two securing screws at the left and right hand side of the front panel and remove the screws. Carefully pull the panel forward at the top and lift clear.
- c) Unlock and open the thermostat access door (top of right-hand cabinet panel).
- d) Turn the thermostat dial to the maximum setting.
- e) Switch the summer/winter switch to the winter position.
- f) Turn on the gas and purge any air from the line.
- g) Remove the burner pressure test point sealing screw from the gas control valve and attach a suitable pressure gauge.
- h) Switch on the electrical supply to the heater.
- i) The automatic ignition sequence will now commence with a pre-ignition purge, and the burner should ignite within approximately 10 seconds; this can be verified by looking through the burner viewing window (immediately above electrode/flame probe).

N.B. If the burner does not ignite during the automatic ignition sequence for any reason, e.g. air in the system, it will be necessary to reset the ignition unit by switching the electrical supply to the heater off and then on again. Alternatively, the summer/winter switch may be switched to off and then winter.

10.2 Testing and Adjusting

- a) With the heater operating, test for gas soundness around all internal gas carrying components. Use a suitable soap solution or leak detection fluid.
- b) Check that the burner pressure is correctly set (see 4.0 Technical Data). If adjustment is necessary, remove the pressure adjuster cover at the rear of the valve and turn the pressure adjuster (clockwise to decrease). Replace the cover after adjustment.
- c) Switch off the electrical supply to the heater.
- d) Remove the pressure gauge and replace the pressure test point sealing screw, ensuring that it is gas tight.
- e) Set the room thermostat (if fitted) to the desired temperature by setting the number on the large dial opposite to the pointer under the dial. The numbers correspond approximately to temperature in degrees celsius. Ensure that the smaller dial immediately below the setting dial is pointing to number 1.

10.3 Completion

- a) Replace the heater front panel:
Position the lower edge of the panel behind the turned edge at the lower front of the heater. Carefully push the front panel towards the heater at the top and secure with the two screws; replace the two covers.

- b) Fit the top and side infill panels using the screws previously removed. Ensure that the rear of the top infill panel engages behind the restraining bracket.

11.0 USER INSTRUCTIONS

Instruct the user in the operation of the heater and hand over the User Instructions.

Advise the user that, for the continued efficient and safe operation of the heater, it is important that annual servicing is carried out, and also the importance of maintaining a clean convection fan filter.

12.0 SERVICING INSTRUCTIONS

IMPORTANT - ALWAYS ISOLATE THE GAS AND ELECTRICAL SUPPLIES TO THE HEATER BEFORE CARRYING OUT ANY SERVICING.

Upon completion of servicing ensure that the heater is tested for gas soundness using a suitable soap solution or leak detection fluid.

12.1 General Access for Servicing

Before any servicing can be carried out, the front panel, and in some cases, the right hand side panel must be removed:

A) To Remove the Front Panel

Remove the two screw covers to expose the two securing screws at the left and right hand of the front front panel and remove the screws. Carefully pull the panel forward at the top and lift clear.

B) To Remove the Right Hand Side Panel.

- a) Remove the front panel as in 12.1A above.
- b) Remove the two screws securing the top infill panel and remove the panel.
- c) Remove the two screws securing the top cabinet panel and remove the panel.
- d) Slacken the two screws securing the right hand side panel at the bottom and lift the panel clear.

12.2 To Remove the Left Hand Side Panel

- a) Follow steps a), b) and c) under 12.1B) above.
- b) Slacken the two screws securing the panel at the bottom and lift the panel clear.

12.3 To Remove the Full Sequence Control Unit

- a) Gain general access as in 12.1A above.
- b) Pull off the terminal block from the unit.
- c) Pull off the igniter cable from the electrode/flame probe.
- d) Remove the two screws securing the unit to the lower inner front panel and remove the unit.

12.4 To Remove the Convection Fan Assembly.

- a) Gain general access as in 12.1A above.
- b) Remove the full sequence control unit as in 12.3 above.
- c) Remove the four screws securing the fan access panel to the heater and remove the panel
- d) Note their relative positions, then disconnect the black and green/yellow wires from the left hand side of the terminal block near the convection fan and pull off the black wire from the resistor.
- e) Remove the four screws and shakeproof washers securing the convection fan to the heater.

- f) Carefully pull the convection fan forward and clear and remove it from the heater.

Note

If the convection fan proves to be faulty and a replacement is to be fitted, the terminal block and resistors must be transferred from the old unit.

12.5 To Remove the Combustion Fan Assembly

- a) Remove the two screws securing the top infill panel to the left hand and right hand infill panels and remove the top infill panel.
- b) Pull off the electrical wires and the earth wire from the combustion fan motor.
- c) Pull off the plastic tube from the steel tube on the combustion fan.
- d) Slacken the hose clip securing the flue outlet hose to the combustion fan and remove the hose.
- e) Remove the three screws securing the combustion fan assembly to the rear of the heater and withdraw the assembly, taking care not to damage the gasket.

REASSEMBLING NOTE

When re-fitting, ensure that the fan outlet is facing to the right when viewed from the rear of the heater.

12.6 To Remove the Burner/Injector

- a) Gain general access as in 12.1A and B above.
- b) Pull off the spark/sensor lead from the electrode.
- c) Remove the five screws securing the panel covering the electrode/probe and remove the cover.
- d) Disconnect and remove the burner supply tube.
- e) Remove the four screws securing the burner to the heater and carefully withdraw the burner, taking care not to damage the gasket.
- f) Unscrew and remove the injector holder.
- g) The injector may now be unscrewed from the holder.
- h) When cleaning the injector, do not use a hard, sharp object, that may damage or enlarge the orifice.

12.7 To Remove the Electrode/Flame Sensor Probe

- a) Remove the burner as in 12.6 above.
- b) Remove the screw securing the electrode/flame sensing probe to the burner flange and remove the probe
- c) When replacing the electrode/flame sensor probe, set the gap between the tip of the probe and the burner to $5.5\text{mm} \pm 0.5\text{mm}$.

12.8 To Remove the Gas Control Valve

- a) Gain general access as in 12.1A and B above.
- b) Disconnect and remove the burner supply tube.
- c) Pull off the electrical plug supplying the gas control valve.
- d) Disconnect the gas union at the inlet to the heater.

- e) Remove the three screws (2 top, 1 bottom) securing the gas control valve to the heater and carefully remove the valve.

REASSEMBLING NOTE

When fitting a replacement valve, the fittings at the inlet and outlet, and the securing brackets, must be transferred from the old valve.

12.9 To Remove the Overheat Switch and/or the Fan Switch.

- a) Gain general access as in 12.1A and B above.
- b) Both switches are located behind the thermostat mounting panel. The overheat switch is the one nearer the rear of the heater.
- c) Pull off the wires from the appropriate switch.
- d) Remove the two screws securing the appropriate switch and remove the switch.

12.10 To Remove the Thermistor

- a) Gain general access as in 12.1A and B above.
- b) Slacken the two screws securing the left hand infill panel to the heater base plate and remove the panel.
- c) Remove the two screws securing the right hand infill panel to the heater base plate and remove the panel.
- d) Slacken the two screws securing the right hand cabinet panel to the heater base plate and remove the panel.
- e) Disconnect the thermistor from terminals 5 and 6 of the room thermostat.
- f) Pull the thermistor from its retaining clip at the left hand side of the convection fan housing.
- g) Unclip and remove the thermistor from the internal wiring.

12.11 To Remove the Summer/Winter Switch

- a) Gain general access as in 12.1A and B above.
- b) Take note of their relative positions, then pull off the electrical connectors from the rear of the switch.
- c) Unscrew and remove the nut securing the switch to the thermostat mounting panel and remove the switch.

12.12 To Remove the Room Thermostat

- a) Gain general access as in 12.1A and 12.1B above.
- b) Pull out the convection fan filter through the right hand side infill panel.
- c) Remove the two screws securing the top infill panel and remove the panel.
- d) Remove the two screws securing the right hand side infill panel and remove the panel.
- e) Remove the screw securing the room thermostat to its bracket at the rear and unhook the bracket.
- f) Take note of their relative positions, then disconnect the wiring from the room thermostat and remove the thermostat.