

**Temcana 3C, 6C
Temcana 3CEM, 6CEM
balanced flue
convector heaters**

Installation and servicing instructions

**PLEASE LEAVE THESE INSTRUCTIONS ADJACENT TO THE GAS METER
OR WITH THE SITE ENGINEER**



Vulcana Gas

30 Bridge Road, Haywards Heath, West Sussex, RH16 1TX

Tel: 01444 415871 • Fax: 01444 441433

Email: sales@vulcanagas.co.uk • Website: www.vulcanagas.co.uk

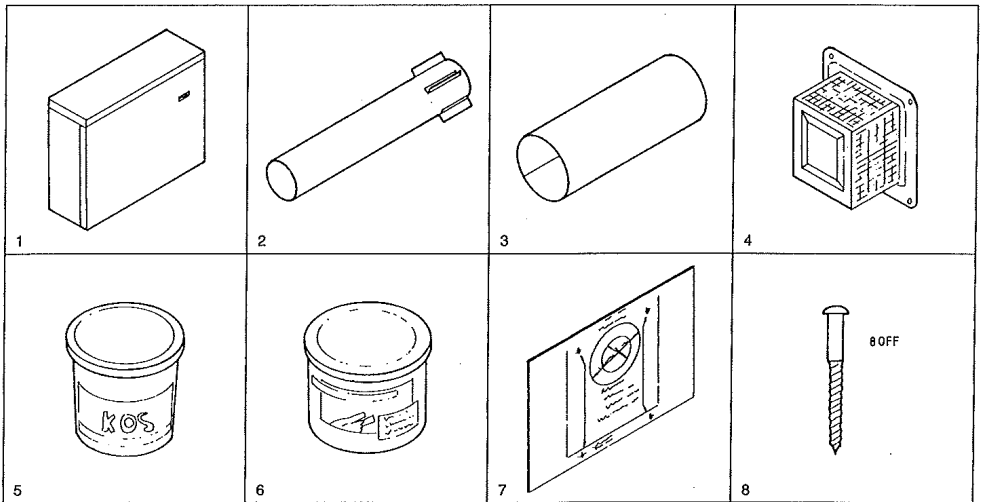

This appliance has been tested and certificated for use on natural gas (G20 at a supply pressure of 20 mbar) and propane (G31 at a supply pressure of 37 mbar) in GB and IE.

INDEX OF CONTENTS

- 1.0 REFERENCE DOCUMENTS
- 2.0 WARRANTY
- 3.0 CONTENTS LIST
- 4.0 TECHNICAL DATA
- 5.0 SITING THE HEATER
- 6.0 TERMINAL POSITION
- 7.0 INSTALLATION
- 8.0 GAS CONNECTION
- 9.0 ELECTRICAL
- 10.0 COMMISSIONING AND TESTING
- 11.0 INSTRUCTIONS TO USER
- 12.0 SERVICING INSTRUCTIONS

1.0 REFERENCE DOCUMENTS

- The appliance must be installed and serviced by a competent person in accordance with:-
 Gas Safety (Installation and Use) Regulations: 1998
 B.S. 6891: 1988
 B.S. 5871: Part 1: 1980
 B.S. 5440: Part 1: 1990
 B.S. 5440: Part 2: 1989
 B.S. 5482: Parts 1 & 2 (Scotland) (Consolidated)
 Local Building Regulations
 Current I.E.E. Wiring Regulations
 Health and Safety Act at work etc. Act: 1984
 Any local Gas Region or Local Authority requirements must also be taken into account.

2.0 WARRANTY

Warranty will be invalidated if the appliance is not installed and adjusted according to the foregoing requirements and the following instructions.

- b) The burner pressure is correctly set. (See Installation Instructions – Commissioning and Testing.)
- c) The balanced flue is clean, unobstructed and is clearing the flue products effectively.
NOTE: Unless otherwise stated, always reassemble in reverse order.

12.1 General Access for Servicing

Before any servicing can be carried out, the case must be removed:–

- a) Remove the two Hexagon headed screws and washers situated at the bottom rear of the case left and right hand side.
- b) Pull the bottom of the case forward sufficient to clear the lower fixing bracket and move the case to the right so that the two mushroom headed top location pins line up with the 'Key holes' in the case. Lift the case clear of the two pins and carefully move it forward and away. Store in a safe place until servicing is complete.

12.2 To Remove the Thermocouple

- a) Gain general access as in 12.1 above.
- b) Release the plastic cable straps tying the thermocouple to the pilot tube.
- c) Disconnect the thermocouple at the control valve and the pilot assembly and remove from the heater.

REASSEMBLING NOTE

When reassembling, avoid excessive tightening at the gas control connection. The correct tightness is finger tight plus ¼ turn.

12.3 To Remove the Spark Electrode

- a) Gain general access as in 12.1 above.
- b) Disconnect and withdraw the thermocouple from the pilot assembly.
- c) Disconnect and withdraw the spark electrode from its housing.

12.4 To Remove the Piezo Unit

- a) Gain general access as in 12.1 above.
- b) Pull off the igniter cable from the piezo unit
- c) Slacken the screw securing the plastic control valve cover to the control valve and remove the cover; the piezo may now be pulled out of the cover.

12.5 To Remove the Gas Control Valve

- a) Gain general access as in 12.1 above.
- b) On EM models, slacken the screw securing the mains plug to the solenoid valve coil and pull off the plug.
- c) Disconnect and remove the main burner supply tube.
- d) Disconnect the pilot supply tube and the thermocouple from the gas control valve.
- e) Release the thermostat phial from its bracket by gently 'springing' the top arm of the bracket upwards whilst gently pulling out the phial.
- f) Disconnect the inlet gas supply tubing at the gas control valve.
- g) Remove the two screws securing the gas control valve to the heater inner right side panel and remove the valve.

Reassembling note

When fitting a new gas control valve, the fittings at the inlet and outlet must be transferred from the old valve (including the solenoid valve if the heater is an EM model).

12.6 To Remove the Main Burner

- a) Gain general access as in 12.1 above.
- b) Disconnect and remove the main burner supply tube.
- c) Remove the nut and washer securing the burner at the left hand end.
- d) Remove the four screws securing the burner flange at the right hand end and withdraw the burner, taking care not to damage the burner flange gasket.

Reassembling Notes

When reassembling ensure that:–

- i) The threaded stud at the left hand end of the burner is engaged into its locating hole in the left hand end of the heat exchanger. (There is a bracket fitted under the hole to aid alignment.) Do not overtighten the nut.
- ii) The burner flange gasket is in good condition and is positioned correctly relative to the fixing holes before replacing the fixing screws.

12.7 To Gain Access to the Main Burner Injector

- a) Follow steps 12.6 a) and b) above.
- b) The injector is located at the right hand end of the burner and can be unscrewed to remove.

IMPORTANT

The orifice of a gas injector is machined to precision limits. Do not clean with hard sharp objects that could damage or enlarge the orifice.

12.8 To Remove the Pilot Assembly

- a) Gain general access as in 12.1 above
- b) Disconnect and remove the pilot supply tube and injector from the pilot assembly.
- c) Pull off the spark lead from the electrode.
- d) Undo the tubing nut securing the thermocouple at the pilot assembly and pull out the thermocouple probe.
- e) Remove the two screws securing the pilot assembly to the heat exchanger and remove the pilot assembly taking care not to damage the gasket.

Reassembling Notes

When reassembling, ensure that:–

- i) The pilot is replaced with the thermocouple connection towards the front of the heat exchanger.
- ii) The gasket is in good condition and is located correctly relative to the two fixing holes before replacing the fixing screws.

8.0 GAS CONNECTION

- a) The gas connection is Rp $\frac{1}{2}$ (½in. BSP internal).
- b) It is situated at the lower right hand side of the heater.
- c) When connecting the gas supply to the heater, it is essential that a UNION SERVICE TAP is incorporated in the supply in an accessible position adjacent to the heater. (For Propane supplies, this tap must be of the spring loaded type).
- d) The installation serving the heater should be in accordance with CP331:Part 3 (Natural gas) or BS5484:Part 1 (Propane).
- e) Upon completion, pressure test the gas installation for soundness.

8.1 Propane Heaters

WARNING – The propane gas supply to the heater must be regulated to give an Inlet pressure to the gas control valve of 37mbar (14.8in.wg). Failure to regulate the Propane gas supply will result in damage to the gas control valve (Fig. 2).

9.0 ELECTRICAL

(Temcana 3C/EM and 6C/EM only)

IMPORTANT – this appliance must be earthed.

- a) All external wiring to the appliance must be in accordance with I.E.E. wiring regulations and any local regulations which apply. The electrical supply required is 230V 50Hz~. The supply must be fused at 3A.

The coding of the input mains supply is:-
EARTH – GREEN & YELLOW
LIVE – BROWN
NEUTRAL – BLUE

- b) Connect the electrical supply using 24/0.2mm cable to B.S 6500 to the terminal block provided. Ensure that this cable is correctly anchored to the cable clamp provided (located on the gas inlet bracket) and connected to the designated terminals:-

↓ – EARTH

L – LIVE

N – NEUTRAL

Care must be taken to ensure that electrical supply cable will not interfere with the case when fitted.

Clock control contacts or other mains switching devices should switch the live (Brown).

IMPORTANT

There must be no surplus cable left between the terminal block and the cable clamp at the inlet to the heater.

10.0 COMMISSIONING AND TESTING

10.1 INITIAL LIGHTING (refer to fig.2)

- a) Ensure that the electrical supply to the heater is switched off (EM models only).
- b) Turn on the gas supply in the union service tap in the supply and purge any air from the line.
- c) Remove the burner pressure test point sealing screw and attach a suitable pressure gauge.
- d) Turn the control knob A to the pilot only position i.e clockwise as far as it will go.

- e) Push in knob A firmly and whilst holding in knob A, push and release igniter knob B and release.
- f) Whilst continuing to push in knob A, check to see if the pilot is alight by looking through the viewing window. If the pilot is not alight, repeat e) until it does light.
- g) Once the pilot is alight, hold in knob A for a further 10–15 seconds.
- h) Release knob A and the pilot should remain alight. If it does not, repeat e), f), g) and h) but this time, keep knob A pressed in a little longer.
- i) On EM models, switch on the electrical supply to the heater and ensure that the clock, if fitted, is set to an on period.
- j) Turn control knob A to its maximum setting, i.e fully anti-clockwise and ensure that the main burner ignites smoothly from the pilot.

10.2 Testing and Adjusting

- a) With the heater operating, test for gas soundness around all pipework including internal pipework and gas carrying components. Use a suitable soap solution or leak detection fluid.
- b) Check that the burner pressure is correct (see 4.0 TECHNICAL DATA). If adjustment is required, slacken the screw securing the plastic cover and remove the cover. Turn the hexagonal aluminium pressure adjuster at the right hand side of the valve (clockwise to decrease).
- c) Turn control knob A to the pilot only position (star).
- d) Switch off the electrical supply to the heater (EM models only).
- e) Remove the pressure gauge and replace the burner pressure test point sealing screw, ensuring that it is gas tight.

10.3 PILOT ADJUSTMENT

The pilot flame length should be such that it just envelops the thermocouple (approx. 20mm). If pilot adjustment is required, proceed as follows:

- a) Slacken the screw securing the plastic control cover to the control valve and remove the cover.
- b) The pilot adjuster screw is situated at the top, left hand rear of the valve.
- c) Turn the adjuster screw clockwise to decrease the length of the pilot flame
- d) Replace the control valve cover.

11.0 INSTRUCTIONS TO USER

Instruct the user in the operation of the heater and hand over the User Instructions.

Advise the user that, for continued efficient and safe operation of the heater, it is important that regular annual servicing is carried out.

12.0 SERVICING INSTRUCTIONS

IMPORTANT - ALWAYS ISOLATE THE GAS AND ELECTRICITY SUPPLIES TO THE HEATER AND ENSURE THAT THE HEATER IS COOL BEFORE CARRYING OUT ANY SERVICING.

Upon completion of servicing, ensure that:-

- a) The heater is tested for gas soundness using a suitable soap solution or leak detection fluid. (See Installation Instructions – Commissioning and Testing.)

3.0 CONTENTS LIST

The appliance is despatched as an assembled heater unit with the flue and fixing components separately boxed. Identify the various components from Fig. 1 and check to ensure that they are complete and undamaged.

1. Heater unit.
2. *Flue Tube
3. *Air duct } Wall thickness 50mm–355mm
4. Flue terminal
5. Furnace cement
6. Putty
7. Template
8. Pack of screws

*Long flue sets, are available from the manufacturer at extra cost for wall thickness up to 635mm.

4.0 TECHNICAL DATA

(A) Natural Gas

	Temcana 3C/EM	Temcana 6C/EM
Heat Input	2.8kW (9 600Btu/h)	5.6kW (19 100Btu/h)
Main Burner		
Injector Marking	135	190
Burner Pressure	16.0mbar (6.4in.wg)	16.0mbar (6.4in.wg)

(B) Propane

	Temcana 3C/EM	Temcana 6C/EM
Heat Input	2.8kW (9 600Btu/h)	5.6kW (19 100Btu/h)
Main Burner		
Injector Marking	095	125
Burner Pressure	35mbar (14in.wg)	35mbar (14in.wg)

5.0 SITING THE HEATER

- a) When selecting the site for the heater, it is essential to ensure that the flue terminal will also be sited correctly externally (see Terminal Positions).
- b) Generally, the best position for the heater is mid-way along a wall of the room that the heater is to serve; this gives the best circulation effect.
- c) Care must be taken to ensure that no door can be swung in front of the heater.
- d) The heater must not be fitted where long curtains can be closed over it. The hem of any curtain must finish at least 50mm above the top of the heater case.
- e) The heater must never be installed directly onto the floor. A minimum clearance of 63.5mm for Temcana 3C models and 90mm for Temcana 6C models must be maintained between the bottom of the heater and the finished floor level or any floor covering.

5.1 Minimum Clearances

The following minimum clearances are required to gain access to, and allow removal of components during servicing.

	Temcana 3C/EM	Temcana 6C/EM
Left Hand Side	25mm	25mm
Right Hand Side	125mm	292mm
Top	25mm	25mm

N.B. If a shelf is fitted above the heater, a minimum clearance of 200mm is required

6.0 TERMINAL POSITION

6.1 Siting

- a) The terminal must be positioned such that the products of combustion can disperse freely at all times.
- b) The base of the terminal must be a minimum of 300mm above the external ground level.
- c) The terminal should not be installed in a position that will allow the products of combustion to feed back into adjacent doors or windows. Where the terminal is wholly or partly beneath any opening, (that is to say any part of a window capable of being opened, or any ventilator, inlet to a ventilation system or similar openings) ensure that no part of the terminal flue outlet is within 300mm, measured vertically, to the bottom of that opening.
- d) If a terminal is fitted within 850mm of a plastic gutter, an aluminium shield 1.5m long must be fitted to the underside of the gutter immediately above the terminal position.
- e) Where the terminal outlet is less than 2m above the level of any ground, balcony, flat roof or space to which any person has access and which adjoins the wall to which the terminal is fitted, the terminal must be protected by a guard of durable material. (A wire guard for this purpose is available at extra cost).

6.2 Balanced Flue Terminal Position Guide

Terminal Position	Minimum Clearance
i) Directly below an openable window or other opening e.g. air brick	300mm
ii) Below guttering, horizontal soil or drain pipes	300mm
iii) Below eaves or balconies	300mm
iv) Above adjacent ground or balcony level	300mm
v) From vertical soil pipes or drain pipes	75mm
vi) From a surface facing the terminal	600mm
vii) From a terminal facing the terminal	600mm
viii) From internal or external corners	600mm

7.0 INSTALLATION

- a) Where the heat resistance of the floor covering is in doubt, fit a piece of heat resisting material or bright aluminium sheet on the floor directly below the heater.
 - b) For installation through combustible walls, the provisions of B.S. 5440 Part 1 clause 21 must be followed. (A 254mm diameter wall liner is available from the manufacturer at extra cost).
- #### 7.1
- Remove the case assembly:–
 - a) Remove the two hexagon headed screws and washers situated at the bottom rear of the case left and right hand side.

- b) Pull the bottom of the case forward sufficient to clear the lower fixing bracket and move the case to the right so that the two mushroom headed top location pins line up with the 'key holes' in the case.
Lift the case clear of the two pins and carefully move it forward and away. Store in a safe place until installation is complete.
- 7.2 Having chosen the site, use sticky tape to fix the cardboard template (Fig. 1, item 7) onto the wall in the desired position, making sure that:-
- a) The line representing the top of the heater is horizontal.
- b) A minimum clearance of 63.5mm for Temcana 3C models or 90mm for Temcana 6C models, between the line representing the bottom of the heater and the finished floor level is maintained. If the floor has not been surfaced, then adequate allowance must be made for thickness of the surface.
- 7.3 Mark the position of the 165mm diameter hole for the flue from the template onto the wall, by punching through the template with a centre punch or nail.
If the heater is to be fitted onto a timber or other combustible wall, this hole must be increased to accept a 254mm diameter wall liner.
- 7.4 Temporarily remove the template and cut the flue hole through the wall as neatly and accurately as possible.
- 7.5 Reposition the template relative to the hole through the wall and mark the location of the four fixing holes through the template as before.
- 7.6 Remove the template, drill and plug the wall to accept 4 x 1½in. No.8 woodscrews (Fig. 1, item 8).
- 7.7 Fit the heater exchanger assembly (Fig. 1, item 1) to the wall using the 4 x 1½in. No.8 woodscrews provided. (Key holes are provided for the top two.)
- 7.8 From outside the building, insert the air duct (Fig 1, item 3) through the hole in the wall to fit over the large spigot on the back of the heat exchanger and mark for the correct length, i.e. with the air duct finishing flush with the outside wall.
- 7.9 Remove the air duct from the hole and cut to the correct length, ensuring that the end is cut square and any rough edges removed.
- 7.10 Spread a ring of furnace cement (Fig. 1, item 5) approximately 3mm thick x 13mm wide on the inner surface of the air duct at the end to be fitted onto the heat exchanger spigot.
- 7.11 Replace the air duct, wedging it into position with brick or tile chips. Make sure that the air duct is horizontal.
- 7.12 For the brick or similar walls, a sand and cement mixture should now be used to make good between the air duct and the outside wall. *N.B.* If the flue hole is cut reasonably accurately and is no greater than 215mm diameter, making good may not be necessary since the terminal fixing plate will cover the opening.
- 7.13 Insert the flue tube (Fig. 1, item 2) through the air duct with the vanes to the outside of the building. Fully engage the flue tube onto the small spigot on the back of the heat exchanger. Measure the total amount by which the flue tube projects from the surface of the outside wall/end of the air duct and note this dimension (X).
The length to be cut from the **Plain End** of the flue tube = X less 95mm.
- 7.14 Remove the flue tube and cut to the correct length, remembering to cut the plain end of the flue tube, leaving the vanes untouched. Make sure that the end is cut square and any rough edges removed.
- 7.15 Carefully position the terminal (Fig.1, item 4) onto the outside wall, making sure that the large spigot enters the air duct. Ensure that the terminal is positioned squarely and mark the wall in preparation for drilling for the four fixing screws.
- 7.16 Remove the terminal, drill and plug the wall in the marked positions for the 4 x 1½in. No. 8 woodscrews.
- 7.17 For combustible walls, insert a 254mm diameter wall liner through the hole in the wall, its length equal to the total wall thickness.
- 7.18 Check the joint between the air duct and the spigot on the back of the heat exchanger to ensure that it is completely sealed.
If necessary, force additional furnace cement into any unfilled space and finally smooth off.
- 7.19 Spread a ring of furnace cement (Fig. 1, item 5) approximately 3mm thick x 13mm wide to the inner surface of the flue tube at the opposite end to the vanes.
- 7.20 Fit the flue tube to the flue spigot on the back of the heater, with the vanes positioned horizontal and vertical, but ensuring that the spot welded seam is not positioned directly at the bottom. Smooth out excess furnace cement and make sure that the joint is completely sealed.
(Remember that the vanes must be to the outside of the building.)
- 7.21 Apply putty (Fig. 1, item 6) to the wall side of the flue terminal fixing plate, between the groove and the outside edge.
- 7.22 Fit the terminal, ensuring that the spigot on the terminal enter the flue tube and the air duct. Secure the terminal to the wall using 4 x 1½ in. No. 8 woodscrews provided.
- 7.23 If necessary, apply additional putty between the terminal fixing plate and the wall to ensure a weatherproof seal.

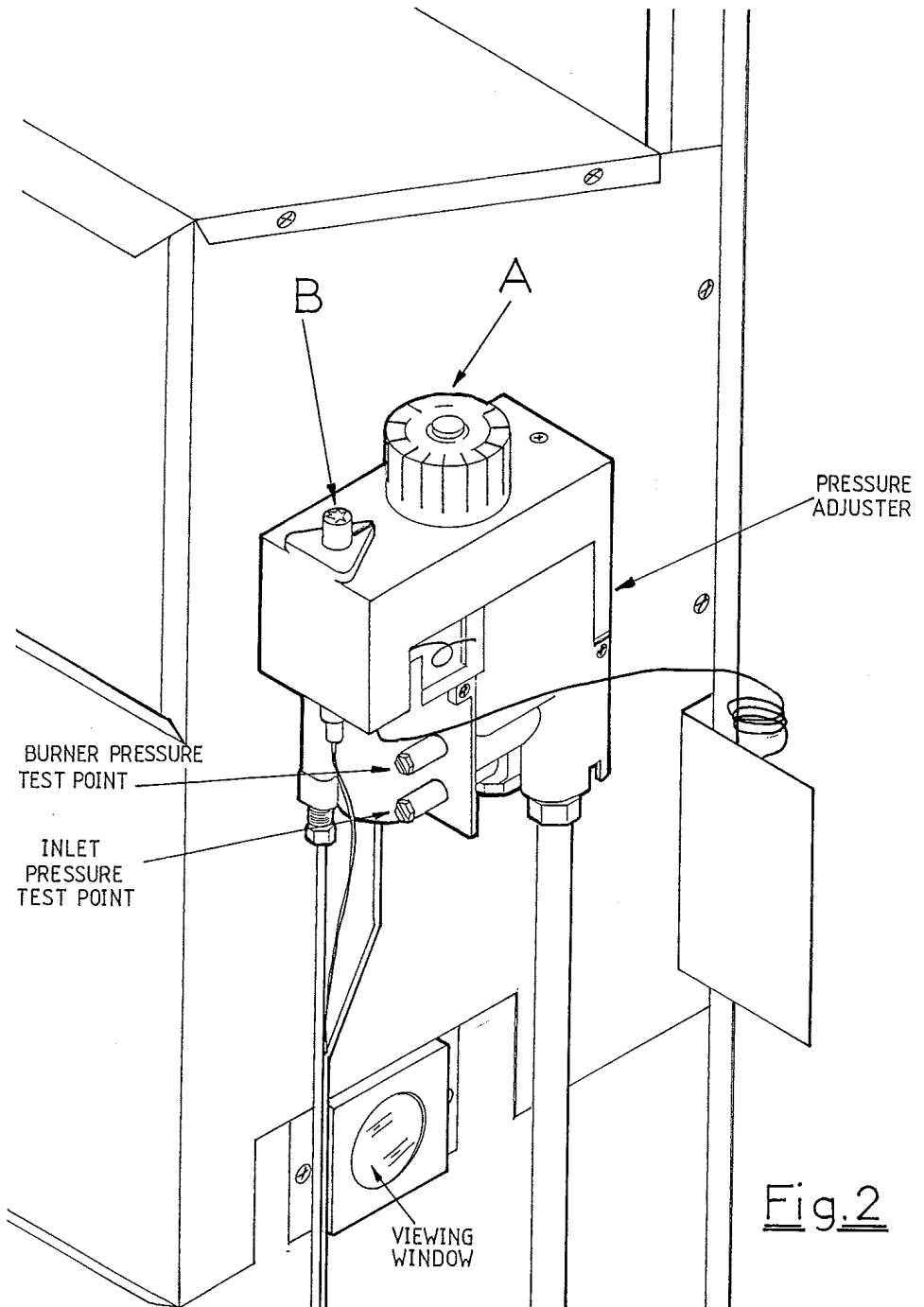

Fig. 2

